

>SISTEM

>SISTEMAPARETE FALMAR



MAPARETE



> NUOVE
PROSPETTIVE
DEL NOSTRO
TEMPO > *NEW
PERSPECTIVE
OF OUR TIME*
> *NOUVELLES
PERSPECTIVES
DE NOTRE
TEMPS*

SISTEMA PARETE

Falmar presenta il Sistema Parete, caratterizzato da un'esclusiva ed ampia collezione di materiali di qualità, capace di creare atmosfere di lavoro autentiche e di realizzare soluzioni su misura che soddisfano le esigenze progettuali e creative più esigenti.

Falmar introduce the Partition System, consisting of exclusive and wide finishes collection and quality, able to combine authentic workplaces and to create custom-made solutions for any creative and particular project.

Falmar présente le système Cloisons Démontables, caractérisé par une vaste collection de matériaux de qualité, capable de créer atmosphères de travail authentiques et de réaliser solutions personnalisées qui satisfont les exigences conceptuelles et créatives plus exigeantes.

TECH FINITURE, ACCESSORI, TECNICI P88



F75

SISTEMA PARETE
MONOVETRO
DOPPIA

P04



F50

SISTEMA PARETE
MONOVETRO

P16



F25

SISTEMA PARETE
MONOVETRO

P30



F200

SISTEMA PARETE
MONOVETRO
ORIZZONTALE

P40



F100_D

SISTEMA PARETE
VETRO DOPPIO

P50



F100_S

SISTEMA PARETE
VETRO SINGOLO

P60



MODULAR

SISTEMA PARETE
DIVISORIA

P70



WALLBOX

SISTEMA PARETE
ATTREZZATA

P80



F75

SISTEMA PARETE **MONOVETRO DOPPIA**

Evoluzione del sistema monovetro con elementi a doppio vetro realizzato con cristalli stratificati antisfondamento sp. 5+5/6+6 mm cadauno e profili in estruso di alluminio rappresentati nella particolare finitura brillantata. Il sistema a doppia monovetro F75 oltre a garantire un'elevata insonorizzazione degli ambienti rappresenta una straordinaria pulizia d'insieme.

Evolution of the single-glass, double-glazed with elements made of layered safety crystals 5+5/6+6 mm thick each and extruded aluminum profiles represented in the particular polished finish. The double glass partition system F75 ensure high soundproof and an extraordinary cleanliness of the whole.

Evolution du système verre simple avec éléments à double verre réalisé avec cristaux feuilletés incassables ep.5+5/6+6 mm chacun et profils d'aluminium extrudé représentés dans la finition chromée. Le système à double verre F75 ne garantit pas seulement une insonorisation élevée des ambiances mais aussi représente une extraordinaire épuration d'ensemble.

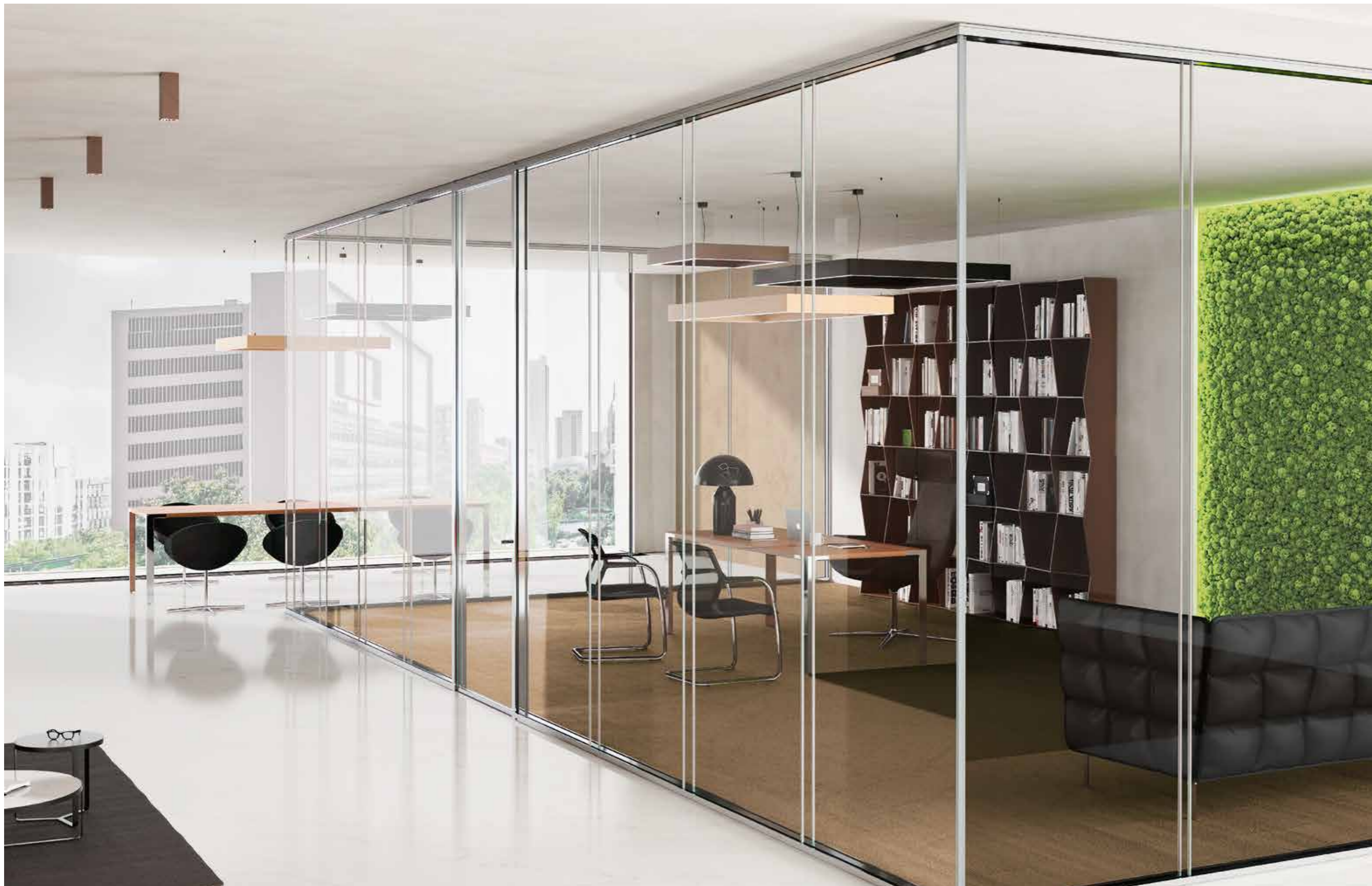



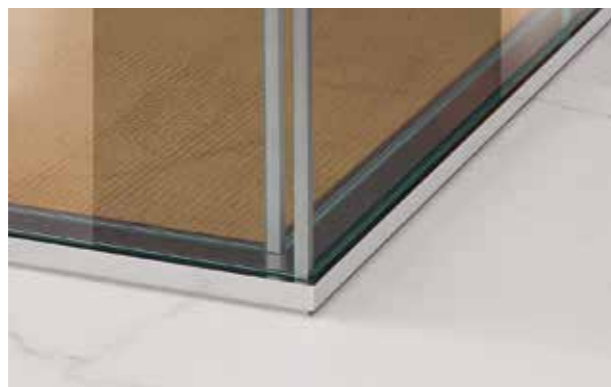

Una parete innovativa che seduce per la sua estetica moderna e la purezza delle sue linee, capace di arredare ed allo stesso tempo insonorizzare gli ambienti nel rispetto della privacy.

Innovative Partition system that appeals thanks to its modern aesthetic and clean lines, able to decorate and insulate at the same time, with respect for the privacy.

Une cloison innovatrice qui séduit pour son esthétique moderne et la pureté des lignes, capable d'aménager et au même temps d'insonoriser les milieux dans le respect de l'intimité.





Contenere, dividere, organizzare: pareti attrezzate con contenitori, indispensabili nell'arredamento dell'ufficio, risolvono brillantemente ogni necessità di archiviazione, abbinandosi nelle finiture e nell'assemblaggio agli altri sistemi Falmar.

To contain, store, organize: equipped walls with cabinets full-height, necessary to solve any need of storage, matching with finishes of the other systems Falmar.

Contenir, partager, organiser: cloisons équipées avec conteneurs toute hauteur, indispensables dans l'aménagement du bureau, peuvent résoudre brillamment chaque nécessité de rangement, et se combinent dans les finitions et dans l'installation avec les autres systèmes Falmar.





F50

SISTEMA PARETE **MONOVETRO**

Sistema parete di forte identità, sp. 100 mm, con vetro stratificato 5+5/6+6 mm e profili in estruso di alluminio anodizzato o verniciato a polveri epossidiche, completo di livellamento a pavimento e a soffitto.

Partition system with strong identity, 100 mm thick characterized by 5+5/6+6 mm laminated glass with extruded aluminum profiles or powder coated, complete of adjustable feet for floor and ceiling.

Système cloison de forte identité, ép. 100 mm en verre feuilleté 5+5/6+6 mm et profils d'aluminium extrudé ou vernis par poudres époxydiques, complet de nivellement au sol et plafond.

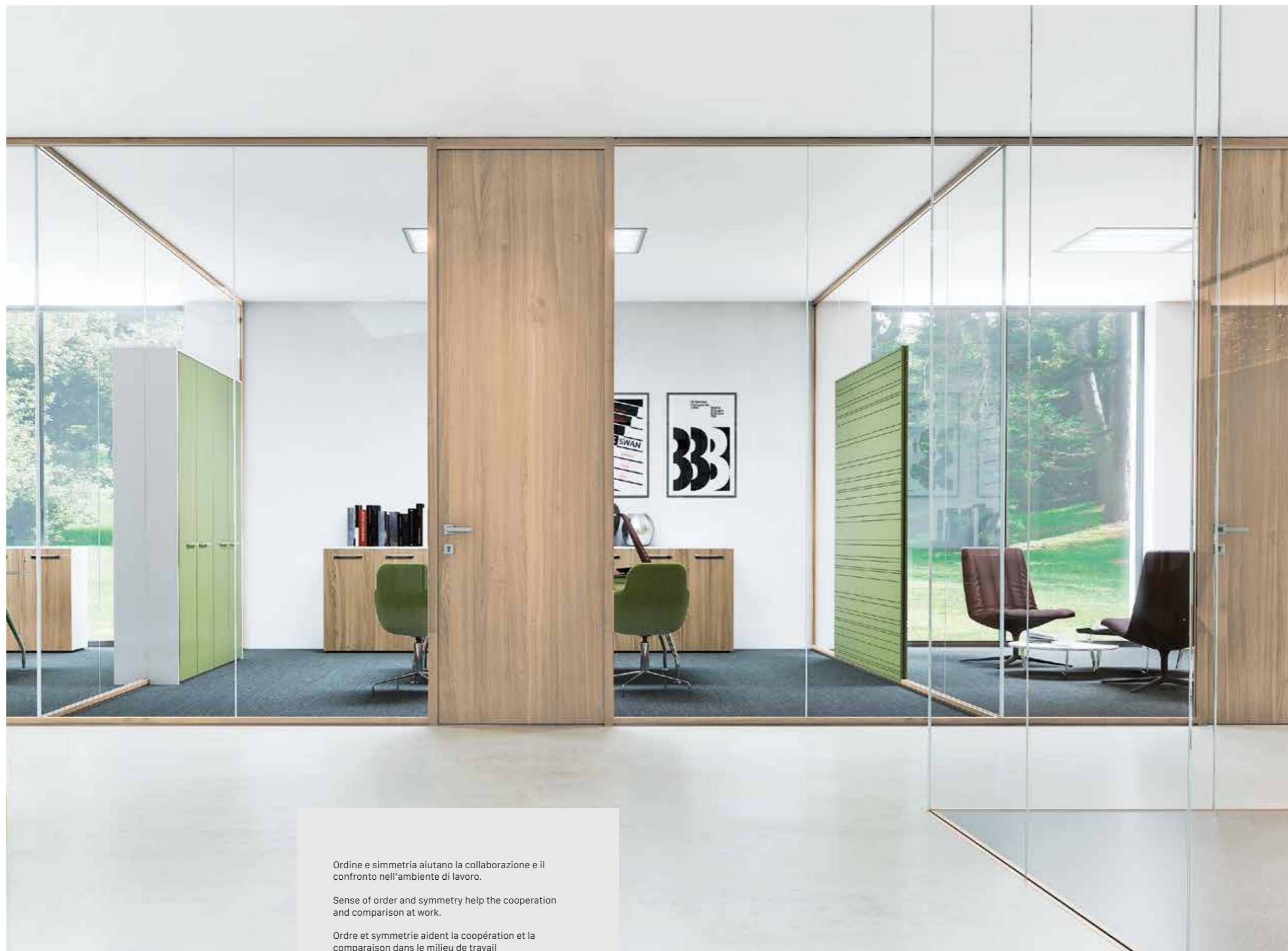

Ordine e simmetria aiutano la collaborazione e il confronto nell'ambiente di lavoro.

Sense of order and symmetry help the cooperation and comparison at work.

Ordre et symétrie aident la coopération et la comparaison dans le milieu de travail







Libera gli spazi, libera la luce
Freeing the space, freeing the light
Degager Les Espaces, Degager La Lumiere







F25

SISTEMA PARETE **MONOVETRO**

Sistema di partizioni sp. 25 mm fortemente caratterizzato dal vetro stratificato sp. 5+5 mm con profili in estruso di alluminio anodizzato o verniciato a polveri epossidiche, completi di piedini idonei per la regolazione millimetrica a pavimento e a soffitto.

Partition System strongly characterized by 25 mm thick laminated glass 5+5 mm with profiles in extruded anodized aluminum or powder coated, complete with adjustable feet suitable for millimeter floor and ceiling.

Système de cloison ep. 25 mm fortement caractérisé par le verre feuilleté ep. 5+5 mm avec profils d'aluminium extrudé ou vernis par poudres époxydiques, complet de pieds de nivellement pour le parfait réglage au sol et au plafond.



Ambienti dominati dalla luce dove le strutture divisorie non creano barriere, ma sono la soluzione ideale per garantire discrezione acustica favorendo l'interazione fra i diversi spazi.

Environments dominated by the light where the divisions do not create barriers, but they are the ideal solution to ensure soundproof and interaction between the different spaces.

Environnements dominés par la lumière où les structures de division ne créent pas une barrière, au contraire sont la solution idéale pour garantir discrétion acoustique en favorisant l'intégration entre les différents espaces.





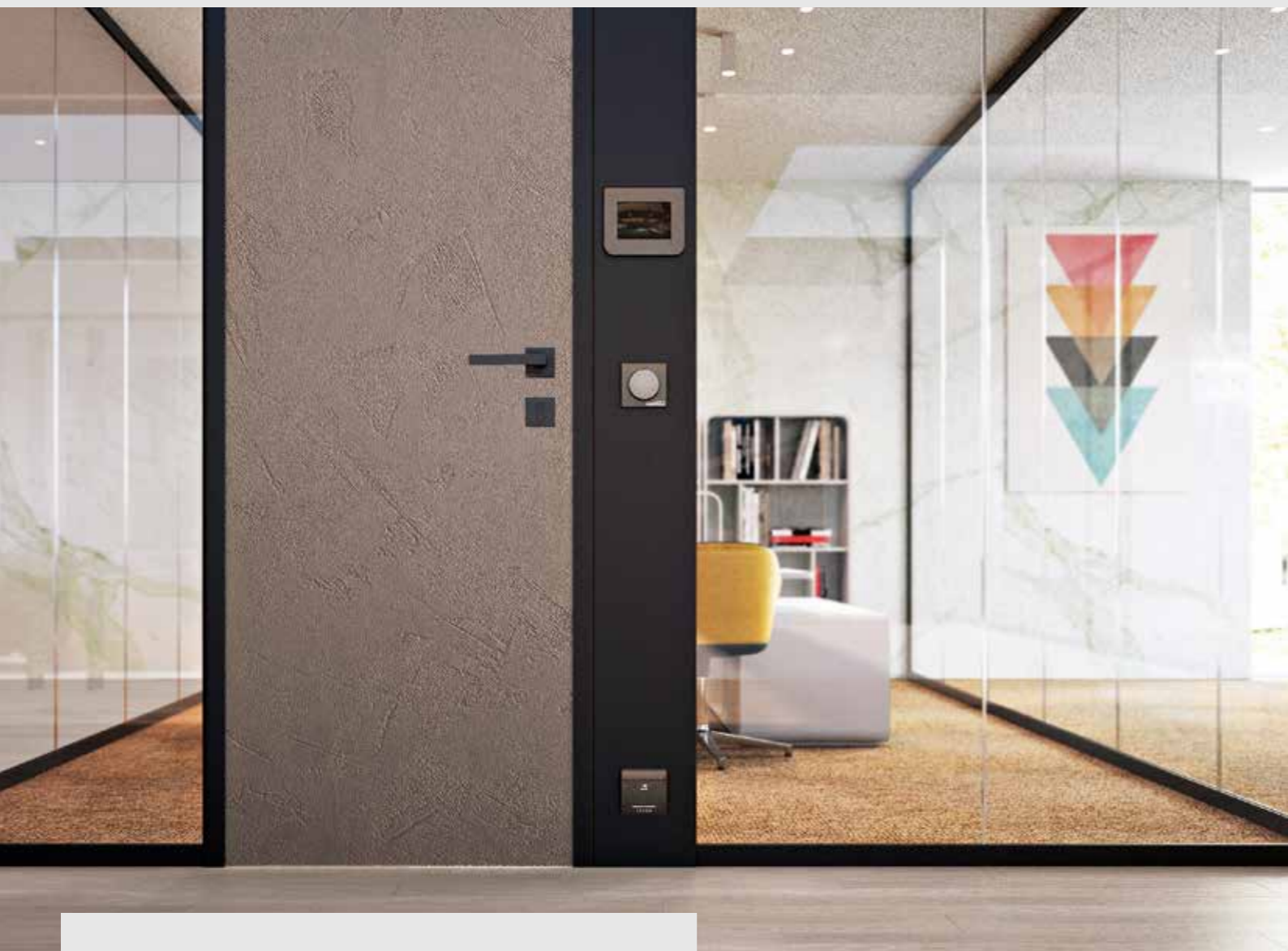

F25 è il sistema tutto vetro perfettamente integrabile con gli altri sistemi di Falmar, che caratterizza il luogo di lavoro con l'eleganza e la sobrietà del design.

F25 all-glass system is fully integrated with other systems Falmar, which characterizes the workplace with the elegance and simplicity of design.

F25 est le système tout en verre parfaitement intégrable avec les autres systèmes de Falmar, qui caractérise le lieu de travail avec son élégance et sobriété de design.







F200

SISTEMA PARETE **MONOVETRO ORIZZONTALE**

Sistema parete sp. 104 mm realizzato con vetro stratificato sp. 4+4 mm a 3 doghe orizzontali uniti tra loro da un particolare profilo in alluminio ad "H". Struttura in acciaio zincato completa di piedini di livellamento e profili porta vetri in estruso di alluminio anodizzato o verniciato a polveri epossidiche.

Partition System thickness 104 mm made of laminated glass 4+4 mm thick and 3 horizontal panels joined together by a special "H" aluminium profile. Galvanized steel structure complete with leveling feet, glass and door profiles made of extruded anodized aluminium or powder coated.

Système cloison ép. 104 mm réalisé en verre feuilleté ép. 4+4 mm à 3 lattes horizontales jointes entre eux par un particulier profil en aluminium en «H». Structure en acier galvanisé complète de pieds de nivellement et profils qui supportent le verres en aluminium extrudé ou vernis par poudres époxydiques.



F200 trasforma l'ufficio in uno spazio aperto. Il minimalismo delle strutture in alluminio e la continuità dei moduli vetrati con particolari decorazioni personalizzate, donano all'ufficio un design unico e suggestivo.

F200 turns into an open space office. The minimalism of aluminum structures and the continuity of the glass elements with special decorations, give unique and charming design to the office.

F200 transforme le bureau dans un espace ouvert. Le minimalisme des structures en aluminium et la continuité des modules vitrés avec particulières décorations donnent au bureau un design unique et suggestif.







Ricevere, confrontarsi, collaborare.
Operatività e discrezione.

*Receive, compare, collaborate.
Efficacy and discretion.*

*Recevoir, se confronter, cooperer.
Operativite et discretion.*







F100 D

SISTEMA PARETE VETRO DOPPIO

F100_D, design, stile, personalizzazione e completezza di finiture. Elementi a doghe con vetri doppi temperati e/o stratificati di sp. 5/6 mm e un sottile alluminio portavetro caratterizzano la trasparenza tra i luoghi di lavoro.

F100_D, design, style, full range of finishes. Slatted double-glazed partition and/or laminated thickness 5/6 mm and thin aluminum glass frame, to create a transparent environment between the workplace.

F100_D design, style, personnalisation et gamme complète de finitions. Éléments à lattes avec verres doubles trempés et/ou feuilleté d'épaisseur 5/6 mm et un mince support pour le verre en aluminium caractérisent la transparence entre les lieux de travail.



Eleganza e sobrietà per una chiara divisione degli spazi, il sistema F100_D crea ambienti di lavoro ben definiti e luminosi.

Elegant and serious collection for a clear office space partition, F100_D creates bright and well-defined work environments.

Élégance et sobriété pour une vision claire des espaces, le système F100_D crée milieux de travail bien définis.







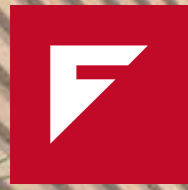

F100 S

SISTEMA PARETE VETRO SINGOLO

F100_S è un sistema pareti realizzato "su misura" progettato per utilizzare tutto lo spazio disponibile. Elementi a doghe con vetri singoli temperati e/o stratificati di sp. 5/6 mm senza tamponamenti, sia a pavimento che a soffitto, rendendo questa parete adatta, per la sua solidità, ad ogni situazione.

F100_S is a Partition System tailor-made "designed to make the best use of all available space. Slatted windows with tempered single and/or laminated glass, thickness 5/6 mm without filling panels both on the floor and ceiling. This partition is therefore suitable for every situation.

F100_S est un système cloison réalisé «à mesure» conçu pour utiliser tout espace disponible. Éléments à lattes avec verres simples trempés et/ou feuilleté d'ép. 5/6 mm sans remplissage, soit au sol qu'au plafond, rendent cette cloison adaptée, pour sa solidité, à chaque situation.

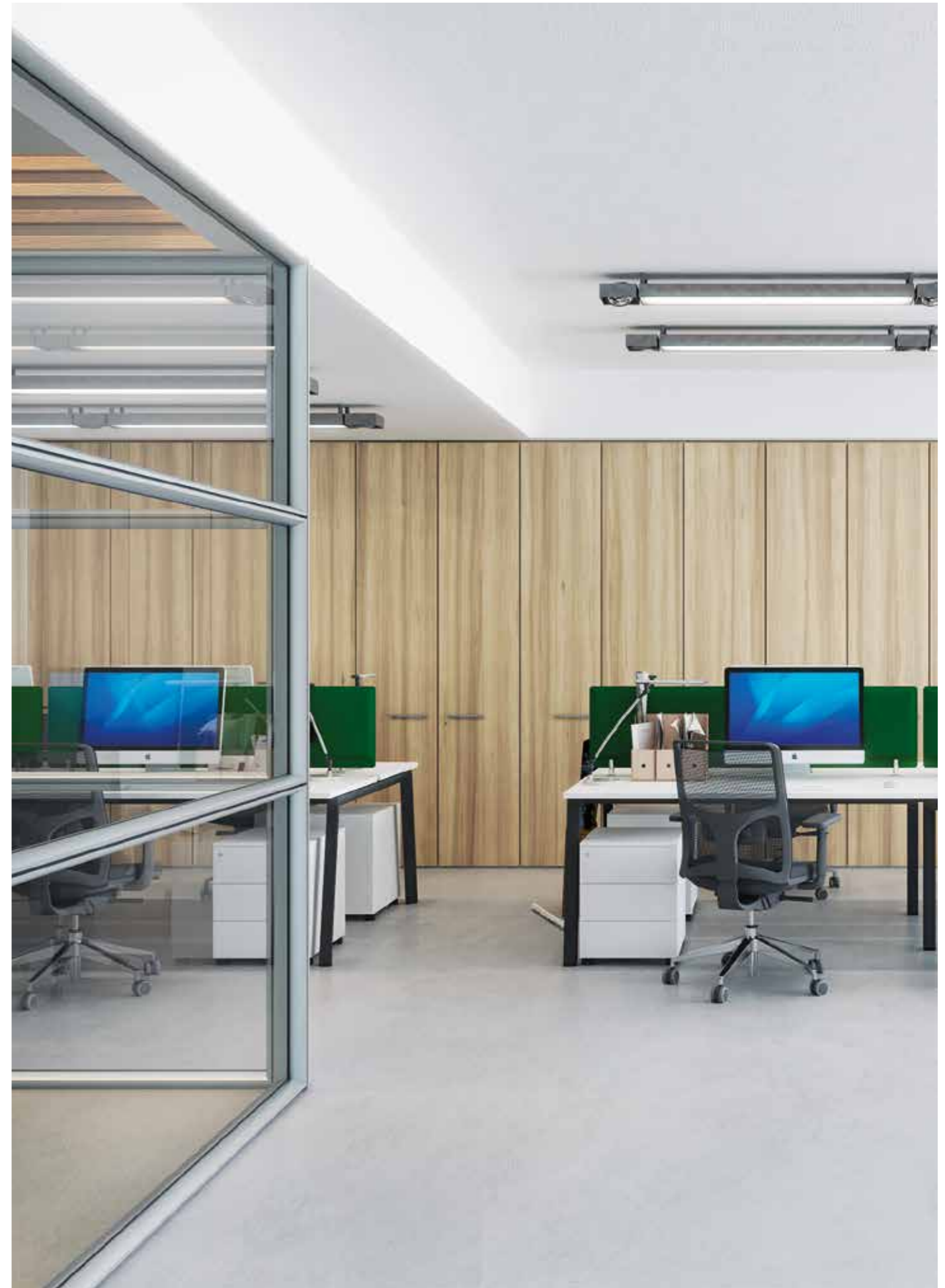



Ottimizzare lo spazio
nel segno dell'ordine.

*Optimize the space
in the sign of the order.*

*Optimiser l'espace
en fonction de l'ordre.*

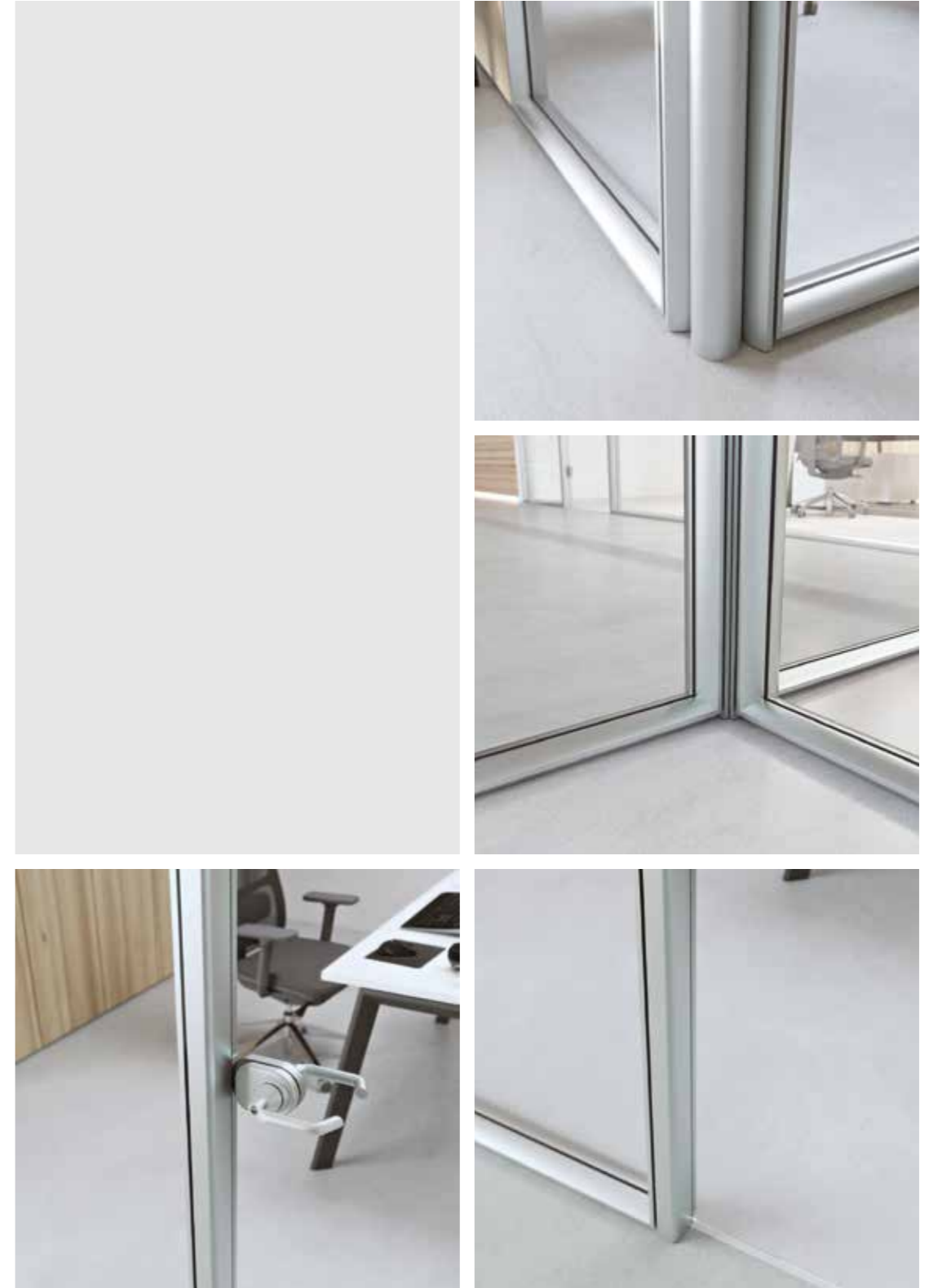





MODULAR

SISTEMA PARETE **DIVISORIA**

L'ambiente lavoro diventa un luogo ben organizzato, dove gli spazi sono gestiti con ordine e chiarezza d'idee. MODULAR è il sistema ideale nella divisione dei grandi ambienti progettato per risolvere ogni problematica grazie alla completa integrazione di pareti divisorie, attrezzate e integrate, proposte in materiali di elevata qualità e con un design attuale ed accattivante.

The work environment becomes well-organized, where the spaces are managed with order and clarity of ideas. MODULAR is the ideal system for large internal divisions thanks to the complete integration between equipped and integrated partitions, submitted with high quality materials, modern and attractive design.

Le milieu de travail devient un lieu bien organisé, où les espaces sont gérés avec ordre et clarté d'idées. MODULAR est le système idéal pour la division de grands espaces conçu pour résoudre n'importe quel problème grâce à l'intégration complète de cloisons démontables, équipées et intégrées, proposées avec matériaux d'haute qualité et un design actuel et séduisant.



La cornice ideale
tra movimento e attesa.

The perfect frame between
movement and waiting.

Le decor idéal entre
mouvement et attente.





Organizzazione a 360°:
 l'esigenza di avere tutto in
 ordine caratterizza il sistema
 di pareti attrezzate MODULAR
 composto da armadiature,
 mensole e cassettiere interamente
 accessoriate per l'archiviazione
 garantendo una perfetta
 insonorizzazione.

*Organization at 360°: the need
 to have everything in order
 characterizes the wall equipped
 system composed by cabinets,
 shelves and pedestals fully
 equipped for storage and able to
 ensure a perfect soundproof.*

*Organisation à 360°: l'exigence
 d'avoir tout rangé caractérise le
 système de cloisons équipées
 MODULAR composé par armoires,
 étagères, caissons entièrement
 équipés pour le rangement qui
 garantit aussi une insonorisation
 parfaite.*







WALLBOX

SISTEMA PARETE **ATTREZZATA**

Un sistema di archiviazione completo: elementi di arredo che dispongono di un'ampia gamma di moduli contenitori, classificatori e mensole. Ante in vetro o in finitura legno o laccata per ogni esigenza estetica e funzionale.

*Complete storage system: wide and full range of modular elements, fillings and shelves.
Glass or wooden doors or lacquered for any design and need.*

*Système d'archivage complet: éléments d'ameublement avec une gamme complète d'armoires, classeurs et étagères.
Portes en verre, bois ou laquées pour chaque exigence de décor et fonctionnelle*







Cerniera con apertura a 90° su fianco con cremagliera alluminio.

Hinge with 90° opening on the side with aluminium rack.

Charnière avec ouverture 90° sur le côté avec crémaillère en aluminium.



Cerniera con apertura a 180°.

Hinge with 180° opening.

Charnière avec ouverture 180°.



Aggancio ripiano metallico su fianco con cremagliera alluminio.

Metal shelf connector on side with aluminium rack.

Fixage étagère métallique sur coté avec crémaillère aluminium.



Aggancio ripiano legno.

Wooden shelf connector.

Fixage étagère bois.



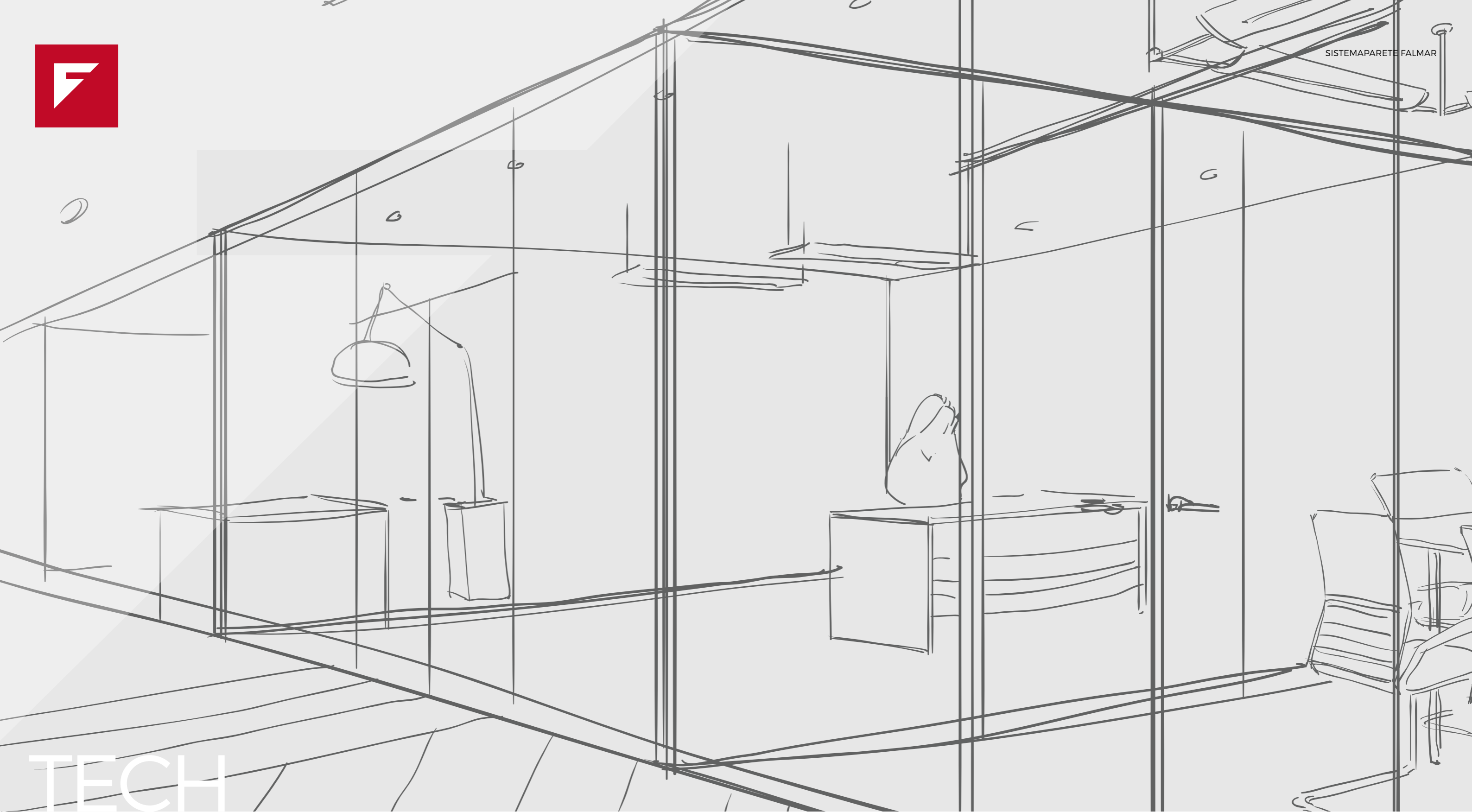

TECH

FINITURE PROFILI E PANNELLI
TECNICI
MURATURA
MANIGLIE
VANO TECNICO

Panels and profiles finishes, technical data, masonry, handles, technical compartment.

Finitions profils et panneaux, données techniques, maçonnerie, poignées, espace technique.



FINITURE PROFILI

FINITURE PROFILI ALLUMINIO
ALUMINIUM PROFILES FINISHES
FINITIONS PROFILS ALUMINIUM



FINITURE PANNELLI

FINITURE PANNELLI MELAMINICI
MELAMINE FINISHES
FINITIONS PANNEAUX EN MELAMINE

SISTEMAPARETE FALMAR

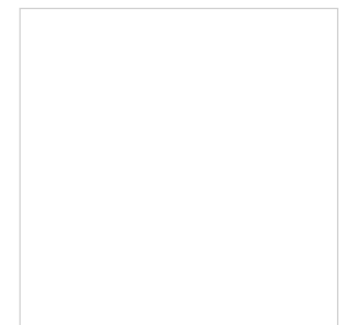

Bianco
White
Blanc



Grigio
Grey
Gris



Argento
Silver
Argent



Alluminio ossidato naturale - verniciato
Natural oxidized - painted aluminium
Aluminium oxidé naturel - vernis



Varianti colore verniciato RAL
Ral colors
Couleurs RAL



Avorio
Ivory
Ivoire



Lino exterio
Flax exterio
Lin exterio



Olmo
Erm
Orme



Olmo Miele
Honey Erm
Orme miel



Alluminio essenza legno
Alluminium wooden essence
Aluminium essence bois



Varianti essenza legno
Wooden options
Options bois

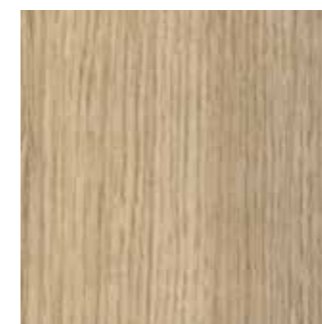

Rovere
Light Oak
Chêne

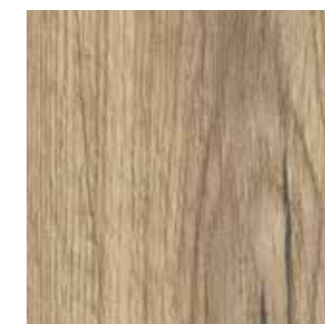

Rovere Sherwood
Sherwood Oak
Sherwood Chêne



Wengé
Dark oak
Chene foncé



Cemento
Cement
Ciment

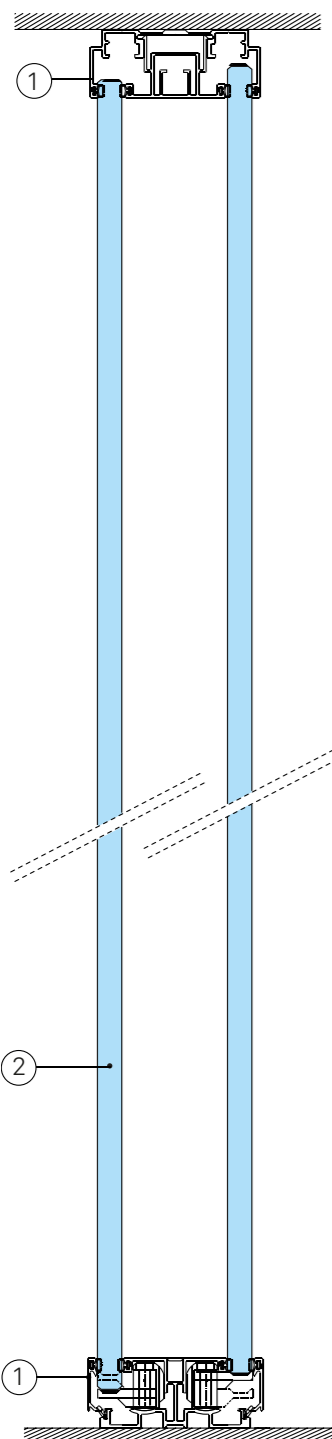
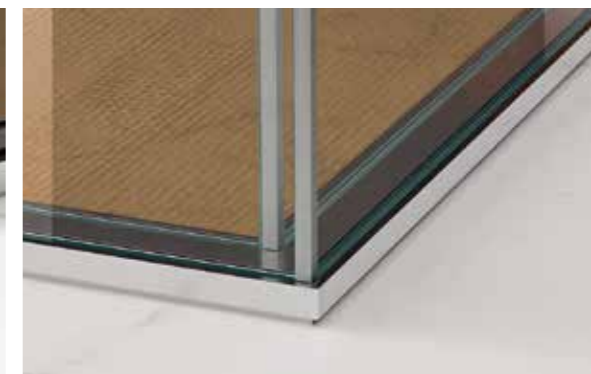

F75

SISTEMA PARETE
MONOVETRO
DOPPIA
SP. 75 MM

Elemento divisorio F75
Partition element F75
Élément de division F75

Sezione verticale
1. Profilo base/soffitto alluminio h. 40 mm
2. Doppio vetro stratificato 5+5/6+6 mm

Vertical section
1. Upper/lower aluminium profile h. 40 mm
2. Double stratified glass 5+5/6+6 mm

Section verticale
1. Profil aluminium sol/plafond h. 40 mm
2. Double verre feuilleté 5+5/6+6 mm

Sezione orizzontale
1. Elemento vetrato doppio
2. Telaio porta
3. Porta vetro lastra doppia intelaiata
4. Porta cieca intelaiata
5. Porta cieca anta legno

Horizontal section
1. Double glass element
2. Door frame
3. Glass door with double framed glass
4. Blind door with frame
5. Wooden blind door

Section horizontale
1. Élément verre double
2. Cadre porte
3. Porte verre double vitrage avec châssis
4. Porte pleine avec châssis
5. Porte pleine en bois

Porta legno/vetro F75
Wood/glass door F75
Porte bois/verre F75

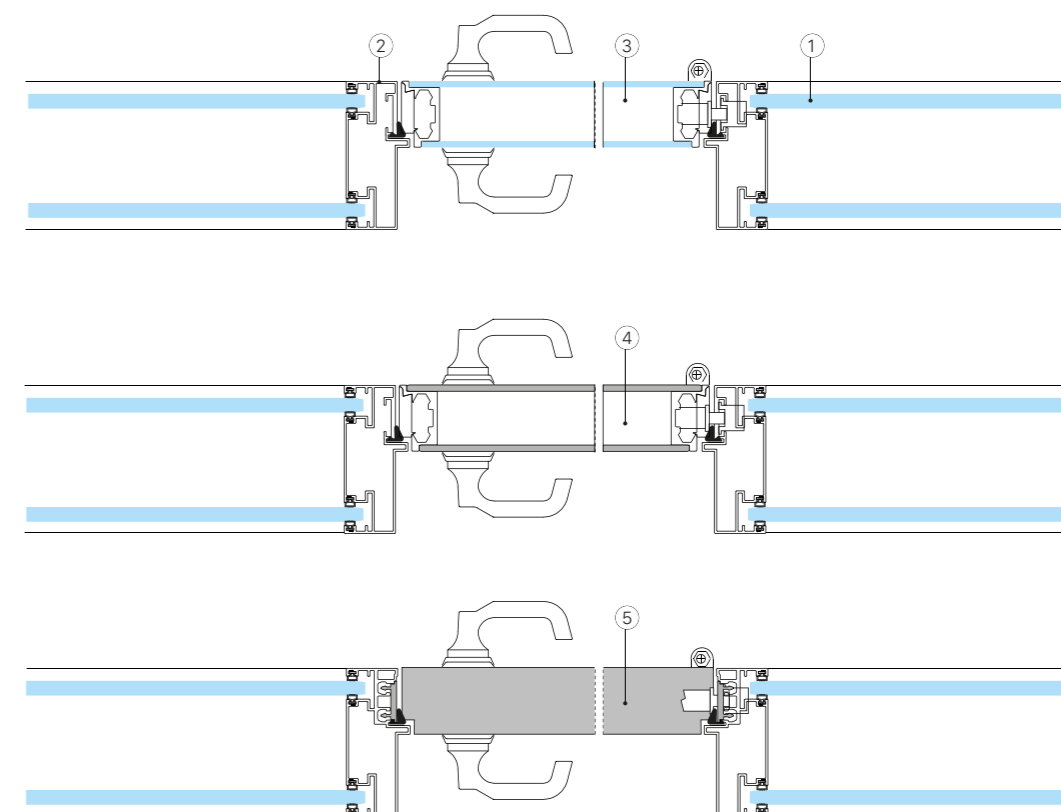

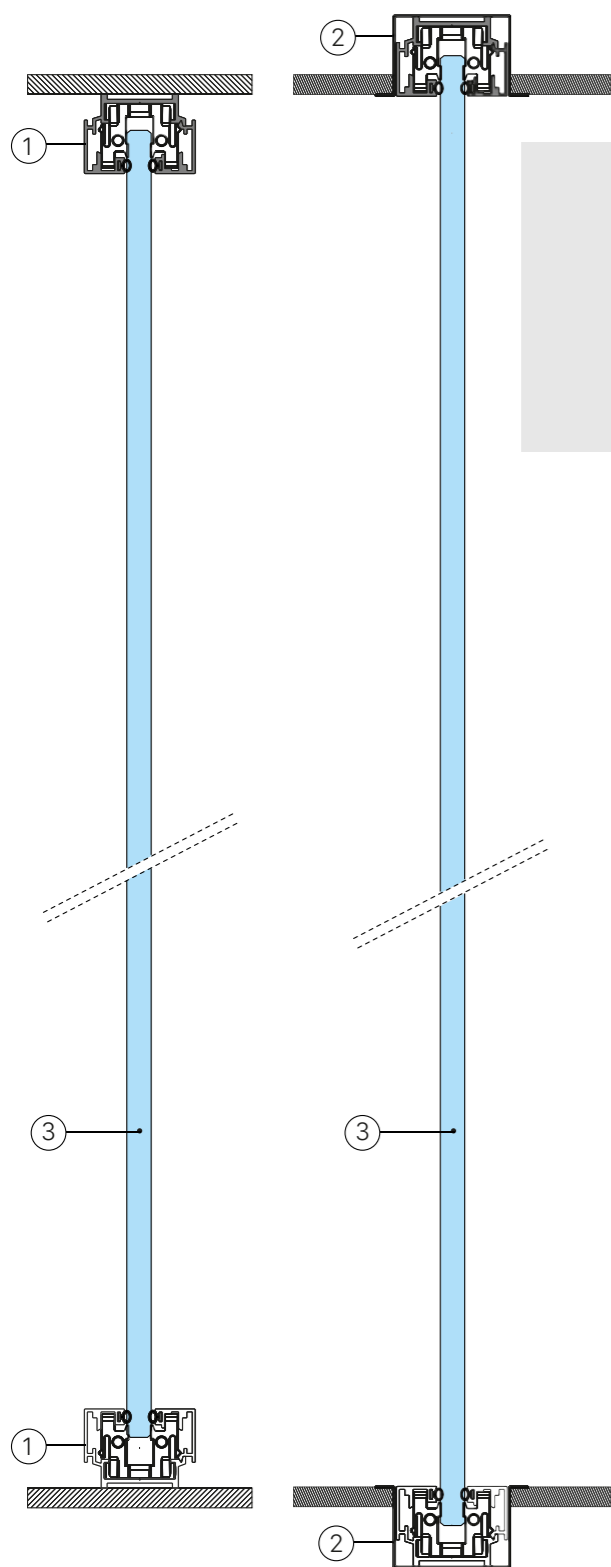

F50
SISTEMA PARETE
MONOVETRO
SP. 57 MM

Elemento divisorio F50
Partition element F50
Élément de division F50

Sezione verticale
 1. Profilo base/soffitto alluminio h. 40 mm
 2. Profilo base/soffitto alluminio incassato
 3. Vetro singolo stratificato 5+5/6+6 mm

Vertical section
 1. Upper/lower aluminium profile h. 40 mm
 2. Upper/lower hidden aluminium profile
 2. Single stratified glass 5+5/6+6 mm

Section verticale
 1. Profil aluminium sol/plafond h. 40 mm
 2. Profil aluminium sol/plafond caché
 2. Verre simple feuilleté 5+5/6+6 mm



Sezione orizzontale
 1. Elemento vetrato singolo
 2. Telaio porta
 3. Porta vetro lastra singola
 4. Porta vetro lastra singola intelaiata
 5. Porta cieca anta legno

Horizontal section
 1. Double glass element
 2. Door frame
 3. Glass door with single glass
 4. Glass door with single framed glass
 5. Wooden blind door

Section horizontale
 1. Élément verre simple
 2. Cadre porte
 3. Porte verre vitrage simple
 4. Porte verre vitrage simple avec châssis
 5. Porte pleine en bois

Porta legno/vetro F50
Wood/glass door F50
Porte bois/verre F50

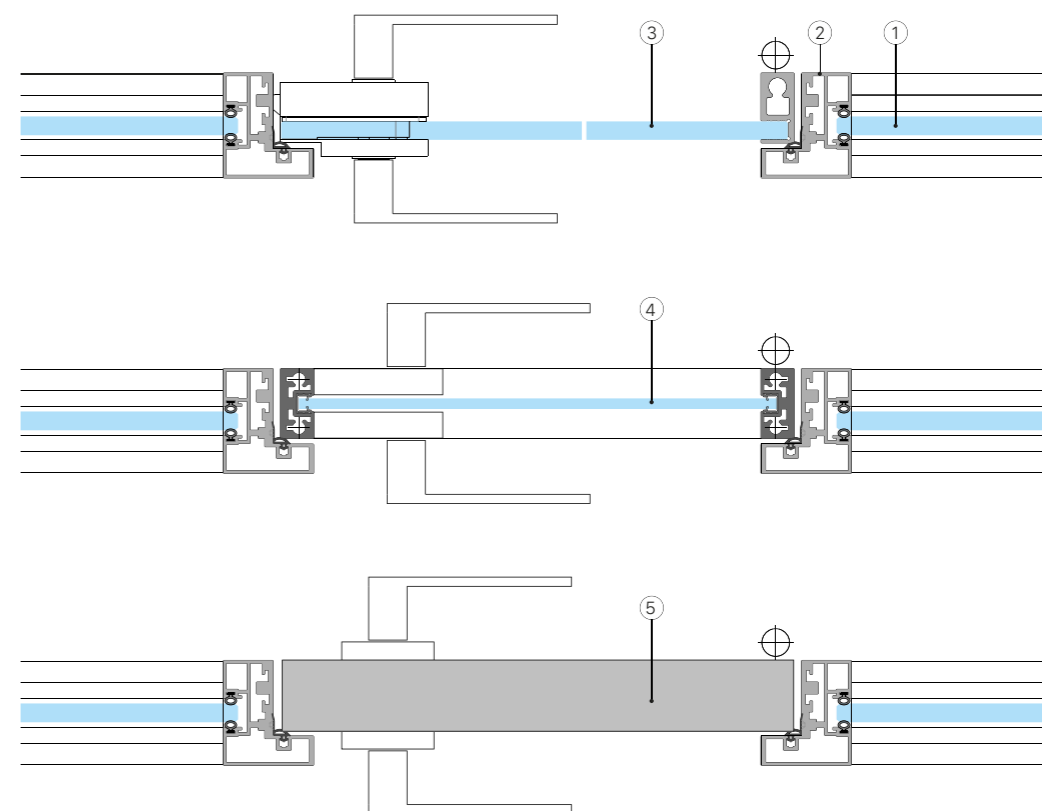

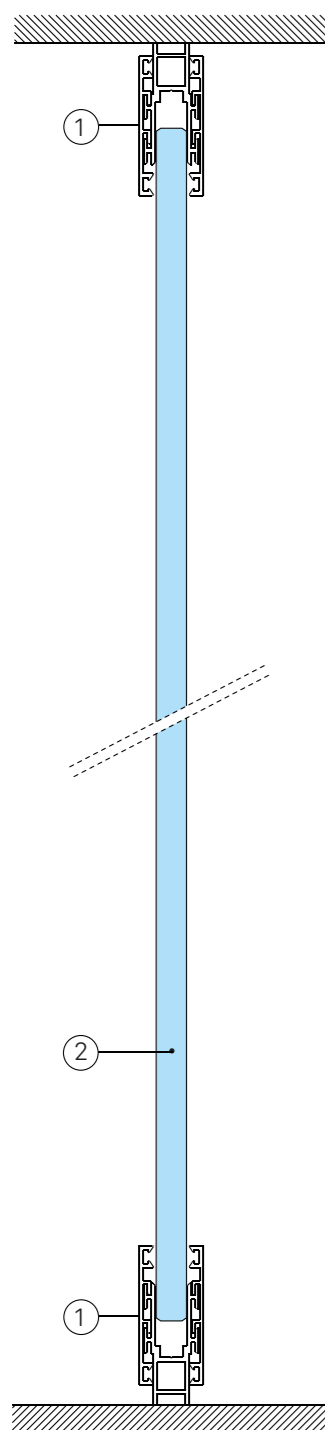

F25
SISTEMA PARETE
MONOVETRO
SP. 28 MM

Elemento divisorio F25
Partition element F25
Élément de division F25

Sezione verticale
 1. Profilo base/soffitto alluminio h. 56 mm
 2. Vetro stratificato 5+5 mm

Vertical section
 1. Upper/Lower aluminium profile h. 56 mm
 2. Stratified glass 5+5 mm

Section verticale
 1. Profil aluminium sol/plafond h. 56 mm
 2. Verre feuilleté 5+5 mm

Porta legno/vetro F25
Wood/glass door F25
Porte bois/verre F25

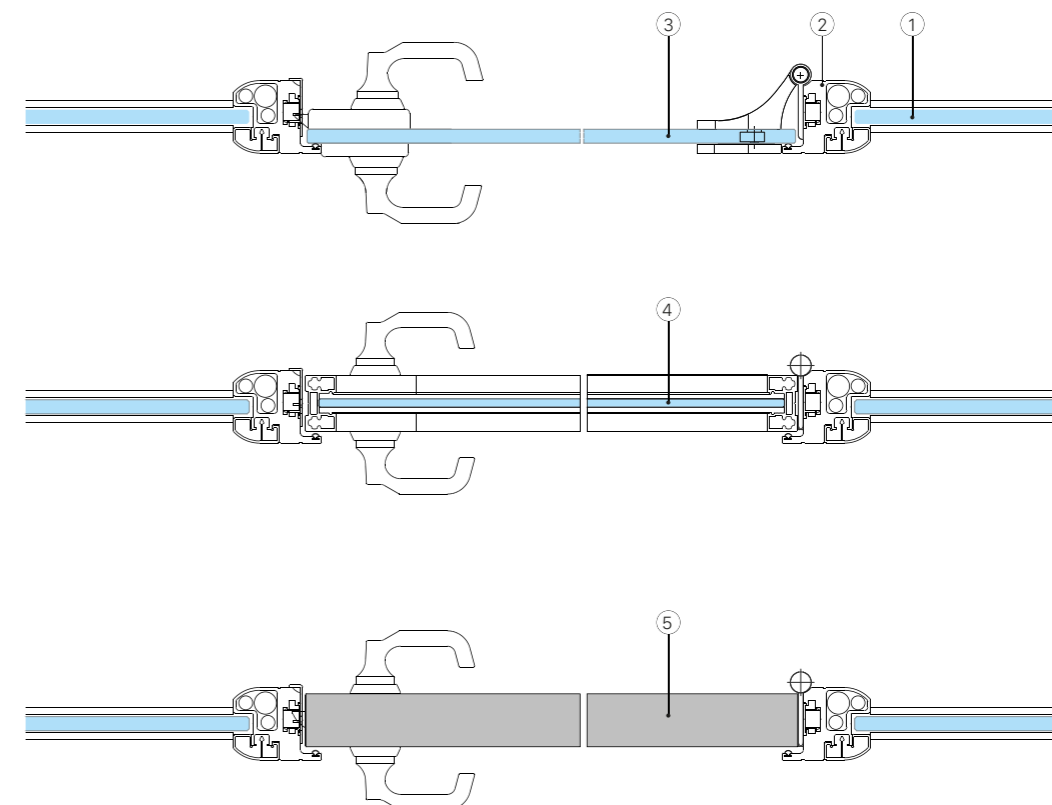

Sezione orizzontale
 1. Elemento vetrato singolo
 2. Telaio porta
 3. Porta vetro lastra singola
 4. Porta vetro lastra singola intelaiata
 5. Porta cieca anta legno

Horizontal section
 1. Single glass element
 2. Door frame
 3. Glass door with single glass
 4. Glass door with single framed glass
 5. Wooden blind door

Section horizontale
 1. Élément verre simple
 2. Cadre porte
 3. Porte verre vitrage simple
 4. Porte verre vitrage simple avec châssis
 5. Porte pleine en bois



F200

SISTEMA PARETE
**MONOVETRO
 ORIZZONTALE**
 SP. 104 MM

Elemento divisorio F200
Partition element F200
Élément de division F200

Sezione verticale
 1.Guida metallica strutturale a pavimento
 2.Profilo alluminio per vetro singolo
 3.Profilo alluminio di giunzione vetro
 4.Vetro stratificato 4+4 mm

Vertical section
 1.Structural metallic floor guide
 2.Aluminium profile for single glass
 3.Aluminium profile for glass junction
 4.Stratified glass 4+4 mm

Section verticale
 1.Glissière métallique structurale au sol
 2.Profil aluminium pour verre simple
 3.Profil aluminium de jonction du verre
 4.Verre feuilleté 4+4 mm

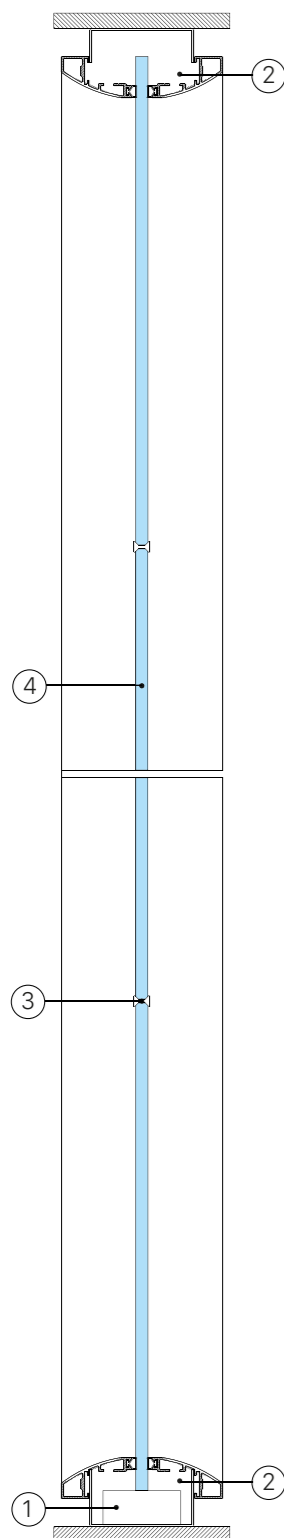

Sezione orizzontale

- 1.Montante strutturale in acciaio zincato
- 2.Profilo alluminio per vetro singolo
- 3.Pannello vetrato singolo 4+4 mm
- 4.Telaio alluminio per porta legno/vetro
- 5.Porta vetro lastra singola
- 6.Porta vetro lastra singola intelaiata
- 7.Porta cieca anta legno

Horizontal section

- 1.Vertical upright in galvanised steel
- 2.Aluminium profile for single glass
- 3.Single glass Panel 4+4 mm
- 4.Aluminium frame for wooden/glass door
- 5.Glass door with single glass
- 6.Glass door with single framed glass
- 7.Wooden blind door

Section horizontale

- 1.Montant structurel acier galvanisé
- 2.Profil aluminium pour verre simple
- 3.Panneau verre simple 4+4 mm
- 4.Chassis aluminium pour porte bois/verre
- 5.Porta verre vitrage simple
- 6.Porta verre vitrage simple avec châssis
- 7.Porta pleine en bois

Porta legno/vetro F200
Wood/glass door F200
Porte bois/verre F200

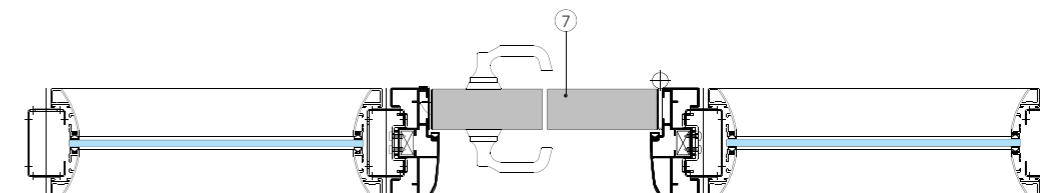
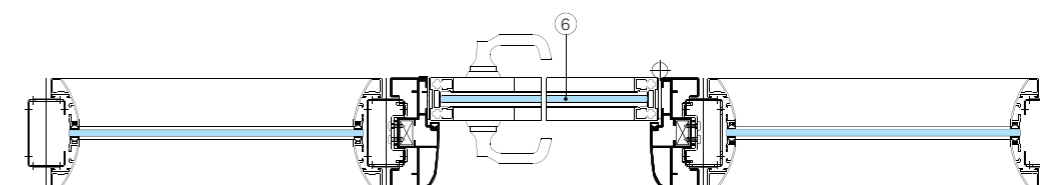
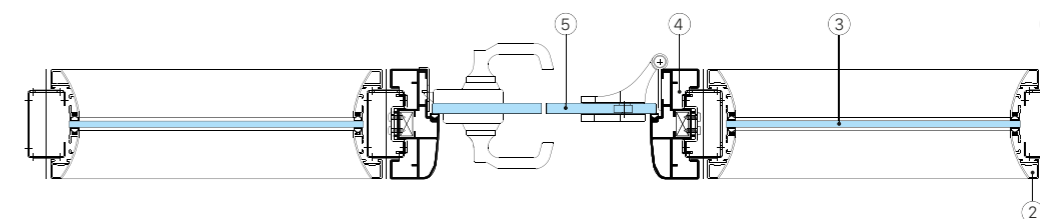



F100_D

SISTEMA PARETE
VETRO DOPPIO
SP. 104 MM

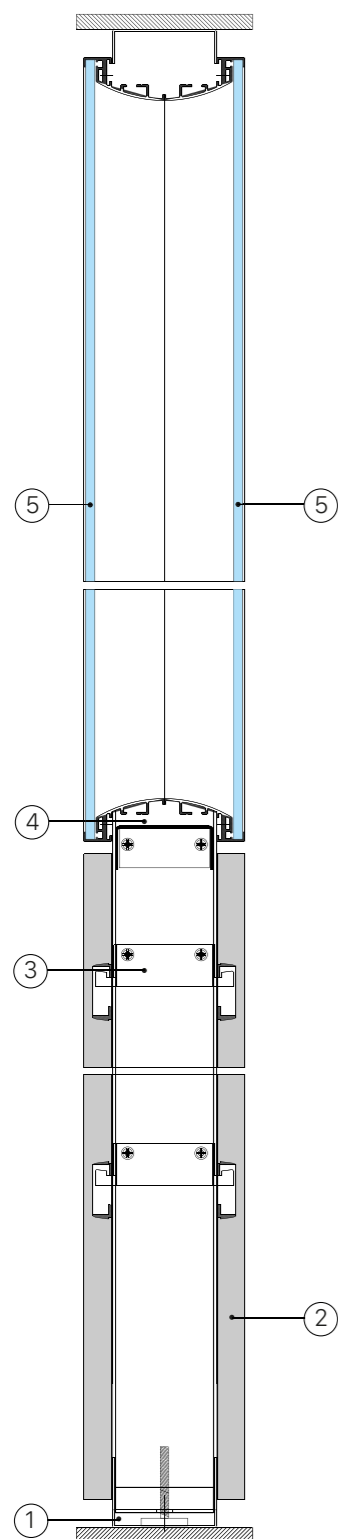

Elemento divisorio F100_D
Partition element F100_D
Élément de division F100_D

Sezione verticale
1.Guida metallica strutturale a pavimento/soffitto
2.Pannello cieco di base
3.Traverso strutturale in acciaio zincato
4.Profilo alluminio per vetro doppio
5.Pannello vetrato doppio

Vertical section
1.Structural metallic floor/ceiling guide
2.Low blind panel
3.Structural galvanized steel transom
4.Aluminium profile for double glass
5.Double glass panel

Section verticale
1.Glissière métallique structurale au sol/plafond
2.Panneau pleine de base
3.Profil transversal structurel en acier galvanisé
4.Profil aluminium pour verre double
5.Panneau verre double



Sezione orizzontale
1.Montante strutturale in acciaio zincato
2.Profilo alluminio per vetro doppio
3.Pannello vetrato doppio
4.Telaio alluminio per porta legno/vetro
5.Porta vetro lastra singola
6.Porta vetro lastra singola intelaiata
7.Porta cieca anta legno

Horizontal section
1.Vertical upright in galvanised steel
2.Aluminium profile for double glass
3.Double glass panel
4.Aluminium frame for wooden/glass door
5.Glass door with single glass
6.Glass door with single framed glass
7.Wooden blind door

Section horizontale
1.Montant structurel acier galvanisé
2.Profil aluminium pour verre double
3.Panneau verre double
4.Chassis aluminium pour porte bois/verre
5.Porte verre vitrage simple
6.Porte verre vitrage simple avec châssis
7.Porte pleine en bois

Porta legno/vetro F100_D
Wood/glass door F100_D
Porte bois/verre F100_D

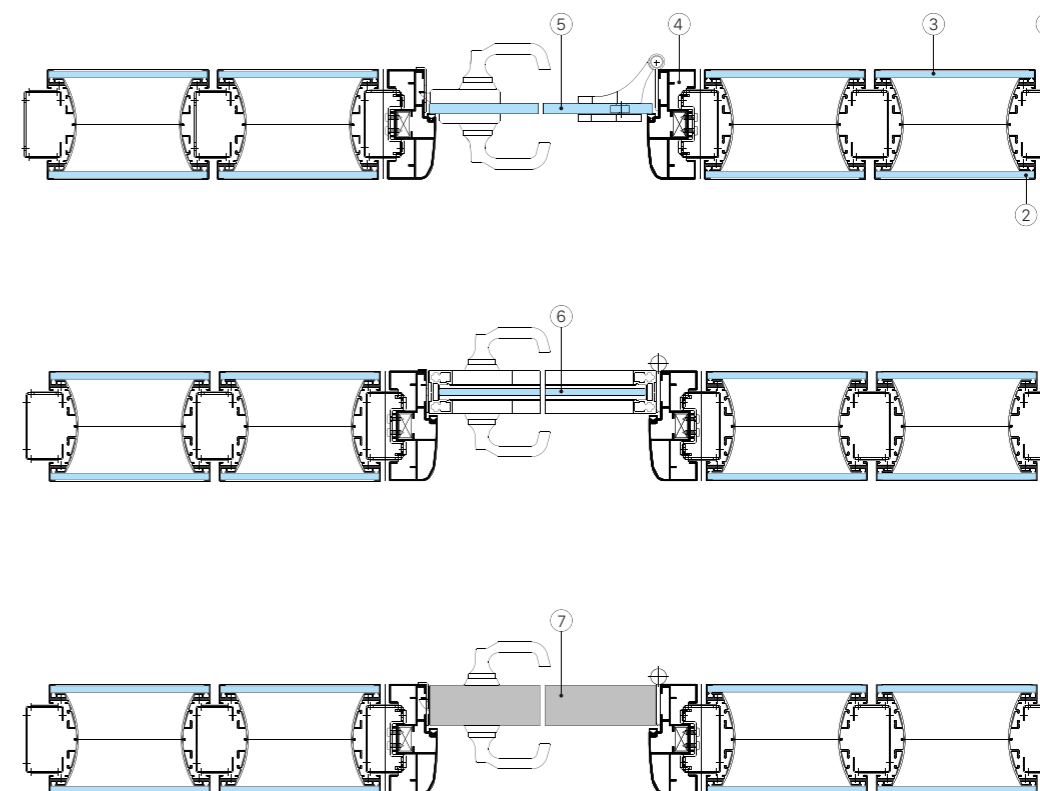



F100_S

SISTEMA PARETE
VETRO SINGOLO
SP. 104 MM

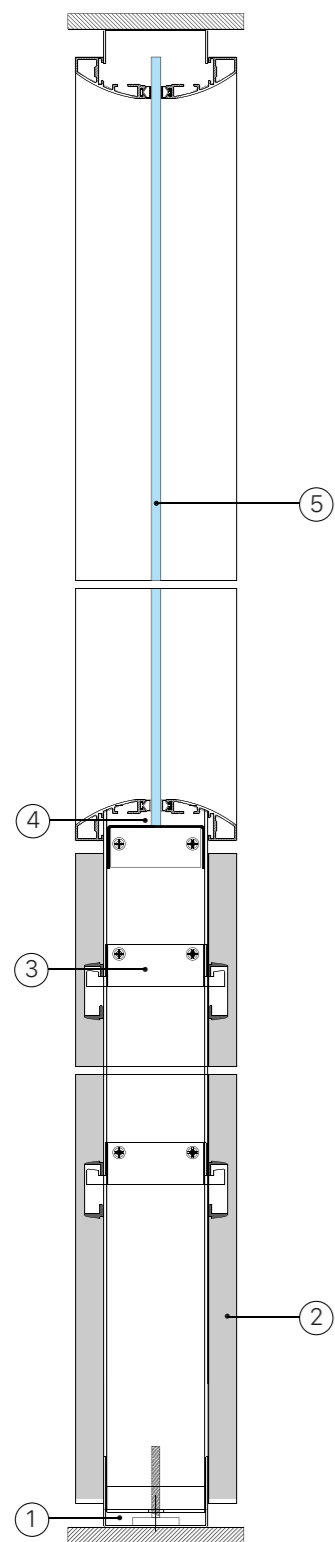

Elemento divisorio F100_S
Partition element F100_S
Élément de division F100_S

- Sezione verticale**
1.Guida metallica strutturale a pavimento/soffitto
2.Pannello cieco di base
3.Traverso strutturale in acciaio zincato
4.Profilo alluminio per vetro doppio
5.Pannello vetrato con vetro singolo

- Vertical section**
1.Structural metallic floor/ceiling guide
2.Low blind panel
3.Structural galvanized steel transom
4.Aluminium profile for double glass
5.Glass panel with single glass

- Section verticale**
1.Glissière métallique structurale au sol/plafond
2.Panneau pleine de base
3.Profil transversal structurel en acier galvanisé
4.Profil aluminium pour verre double
5. Panneau verre avec verre simple



- Sezione orizzontale**
1.Montante strutturale in acciaio zincato
2.Profilo alluminio per vetro singolo
3.Pannello vetrato singolo
4.Telaio alluminio per porta legno/vetro
5.Porta vetro lastra singola
6.Porta vetro lastra singola intelaiata
7.Porta cieca anta legno

- Horizontal section**
1.Vertical upright in galvanized steel
2.Aluminium profile for single glass
3.Single glass panel
4.Aluminium frame for wooden/glass door
5.Glass door with single glass
6.Glass door with single framed glass
7.Wooden blind door

- Section horizontale**
1.Montant structurel acier galvanisé
2.Profil aluminium pour verre simple
3.Panneau verre simple
4.Châssis aluminium pour porte bois/verre
5.Porte verre vitrage simple
6.Porte verre vitrage simple avec châssis
7.Porte pleine en bois

Porta legno/vetro F100_S
Wood/glass door F100_S
Porte bois/verre F100_S

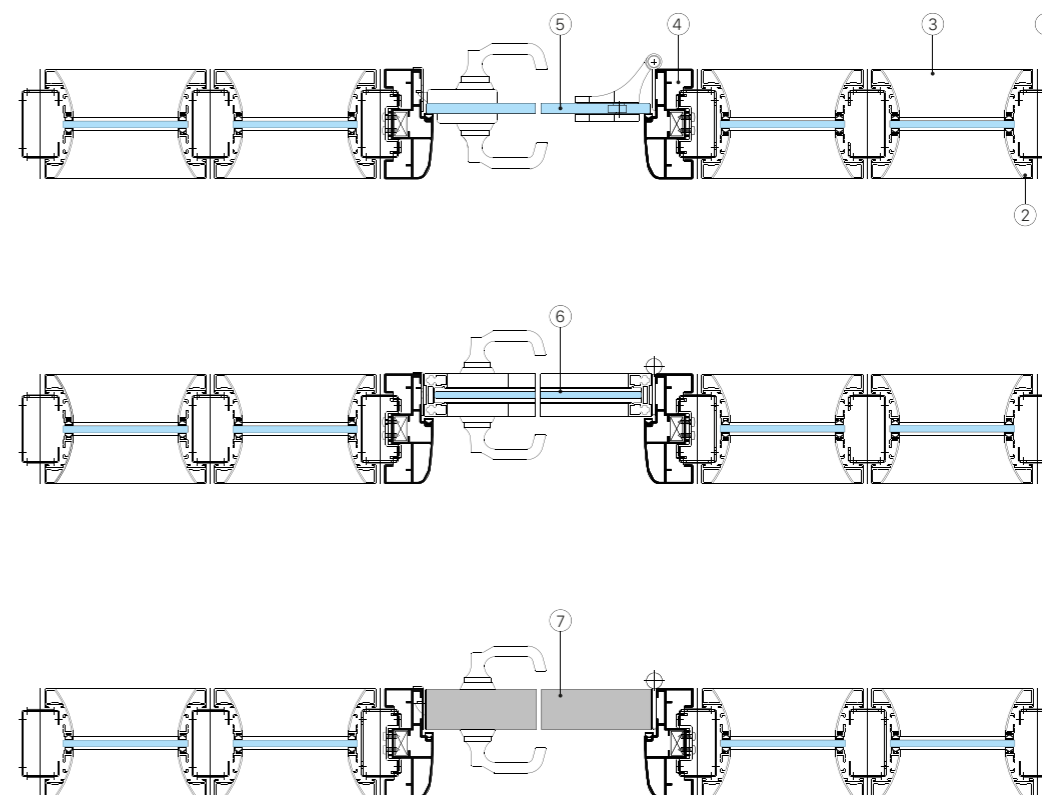



MODULAR

SISTEMA PARETE
DIVISORIA
SP. 104 MM

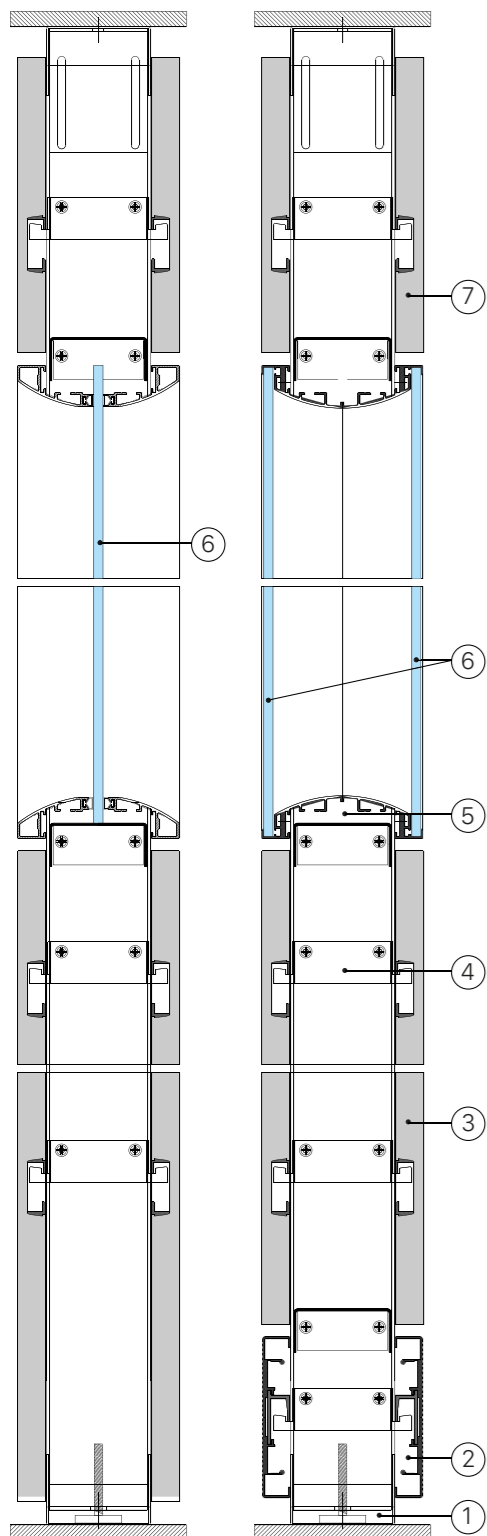

Elemento divisorio Modular
Partition element Modular
Élément de division Modular

Sezione verticale

1. Guida metallica strutturale a pavimento
2. Zoccolatura inferiore in alluminio/legno
3. Pannello cieco di base
4. Traverso strutturale in acciaio zincato
5. Profilo alluminio per vetro singolo/doppio
6. Pannello vetrato con vetro singolo/doppio
7. Pannello cieco di tamponatura a soffitto

Vertical section

1. Structural metallic floor guide
2. Aluminium/wood lower plinth
3. Low blind panel
4. Structural galvanized steel transom
5. Aluminium profile for single/double glass
6. Glass panel with single/double glass
7. Blind panel for ceiling filling

Section verticale

1. Glissière métallique structurale au sol
2. Plinthe inférieure en aluminium/bois
3. Panneau pleine de base
4. Profil transversal structurel en acier galvanisé
5. Profil aluminium pour verre simple/double
6. Panneau verre avec verre simple/double
7. Panneau plein de fermeture au plafond



Sezione orizzontale

1. Montante strutturale in acciaio zincato
2. Profilo alluminio per vetro singolo/doppio
3. Pannello vetrato singolo/doppio
4. Telaio alluminio per porta legno/vetro
5. Pannello cieco di base
6. Porta vetro lastra singola
7. Porta vetro lastra singola intelaiata
8. Porta cieca anta legno

Horizontal section

1. Vertical upright in galvanized steel
2. Aluminium profile for single/double glass
3. Single/double glass panel
4. Aluminium frame for wooden/glass door
5. Low blind panel
6. Glass door with single glass
7. Glass door with single framed glass
8. Wooden blind door

Section horizontale

1. Montant structurel acier galvanisé
2. Profil aluminium pour verre simple/double
3. Panneau verre simple/double
4. Châssis aluminium pour porte bois/verre
5. Panneau pleine de base
6. Porte verre vitrage simple
7. Porte verre vitrage simple avec châssis
8. Porte pleine en bois

Porta legno/vetro Modular
Wood/glass door Modular
Porte bois/verre Modular

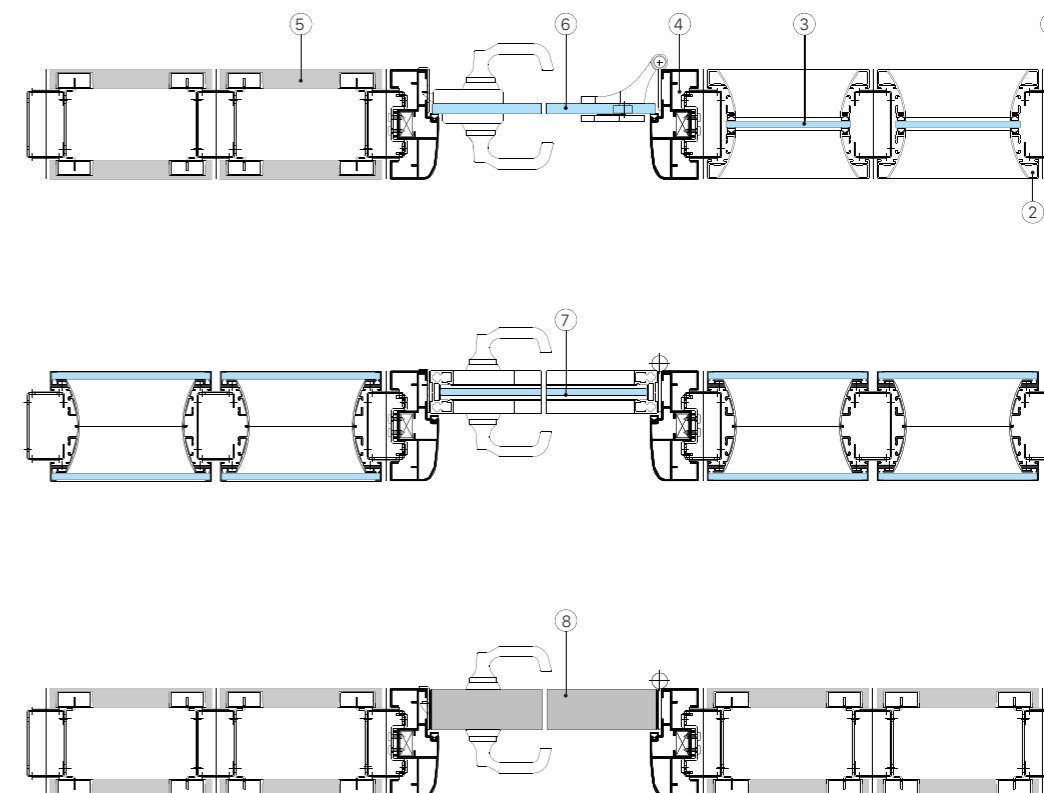



PORTE MURATURA



ANGOLI

Porta legno/vetro in muratura
Wood/glass door in masonry
Porte bois/verre en maçonnerie

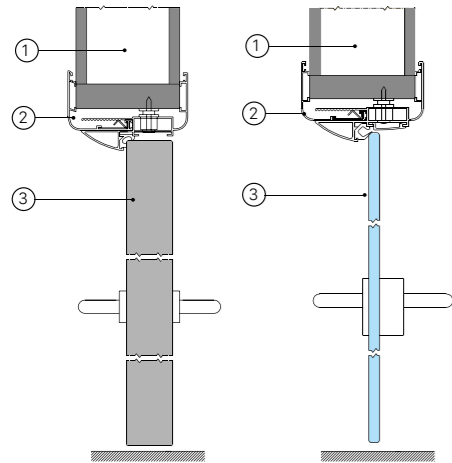

Sezione verticale
Vertical section
Section verticale

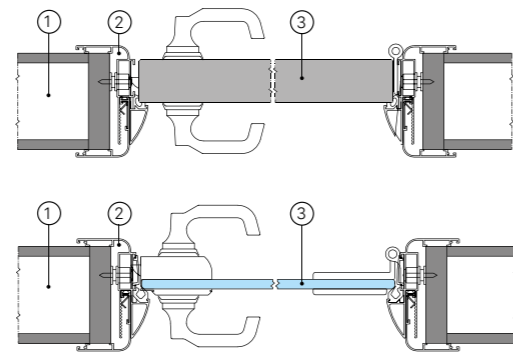

Sezione orizzontale
Horizontal section
Section horizontale

- 1.Elemento vetrato singolo
 - 2.Telaio porta
 - 3.Elemento porta vetro/legno
- 1.Single glass element
2.Door frame
3.Glass/wooden door element
- 1.Elément verre simple
2.Châssis porte
3.Elément porte verre/bois

Angolo di connessione a 90° e/o variabile
90° and/or adjustable corner connection
Angle de connexion à 90° et/ou orientable

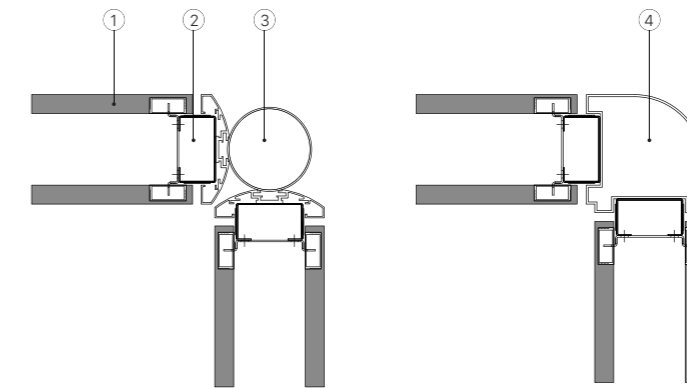

Variabile
Adjustable
Orientable

Fisso 90°
Fixed 90°
Fixe à 90°

- 1.Elemento divisorio
- 2.Montante
- 3.Angolo variabile
- 4.Angolo fisso 90°

- 1.Component partition
- 2.Structural element
- 3.Adjustable corner
- 4.Fixed corner 90°

- 1.Elément de division
- 2.Montant
- 3.Angle de connexion orientable
- 4.Angle fixe 90°





MANIGLIE

MANIGLIE
DOOR HANDLE
POIGNEES



VANO TECNICO

INTERRUTTORI E DOMOTICA
SWITCHES AND DOMOTICS
INTERRUPTEURS ET AUTOMATISATION



Maniglione verticale in acciaio inox con e senza serratura.
Stainless steel vertical handle with or without lock.
Poignée verticale en acier inox avec et sans serrure.

Maniglia porta mod. "QUADRA" alluminio.
Door handle mod. "QUADRA" aluminium.
Poignée porte col. «QUADRA» aluminium

Maniglia porta mod. "HOPPE" alluminio.
Door handle mod. "HOPPE" aluminium.
Poignée porte col. «HOPPE» aluminium.

Maniglia porta mod. "HOPPE" acciaio cromato.
Door handle mod. "HOPPE" chromed steel.
Poignée porte col. «HOPPE» acier chromé.



Interruttore su vano tecnico in alluminio.
Switch applied on technical aluminium compartment.
Interrupteur appliqué sur espace technique en métal.



Interruttore a radiofrequenza su modulo vetrato.
Switch with wireless system applied on glazed partition.
Interrupteur appliqué sur module en verre avec système de radiofréquence.



FALMAR Project s.r.l.

Filippo Callegari, 1/3
61122 Borgo Santa Maria PU • Italy
T. +39 0721 490185 (r.a.)
F. +39 0721 490276

info@falmar.com
www.falmar.com